

Bicycle Storage Eagle Valley MS

Summary

Modern bicycle racks will be installed at Eagle Valley Middle School to meet current demands, encourage increased bicycle use, and reduce bicycle damage. The racks will be placed on existing concrete and on added concrete pads, to create a “bicycle park.”

Bicycle Storage

The bicycle racks near the front entrance to the school are sadly neglected, creating an unwelcome feeling for bicyclists. The traditional racks are bent, placed on dirt and grass which becomes soggy during wet weather and snow, the grass is rarely trimmed around the racks, and a number of old locks are still attached to the racks. A newer rack is completely broken and now presents a tripping hazard to people using the sidewalk. With such an unwelcoming situation, it is surprising that there is any bicycle use at Eagle Valley.



Pads will be installed for three modern bicycle racks, one in the curve of the sidewalk north of the circle, and two in the area with existing bicycle racks. Two of the existing traditional racks will be discarded, and the other two will be retained for fine weather days when a larger number of students bicycle.



Cost

bicycle rack, Bike Rib Series III BR-8 racks with eight bike capacity (3), w/shipping	1905
bicycle rack pads, 6x12 = 72sqft, \$5/sqft (3)	1100
installation of racks and pads	1000
subtotal	\$4005

Source: Function First, Tucson AZ, 888.245.3742, <http://www.bikerack.com/>, or equivalent. Have quote for bicycle rack.

Bicycle Racks for Middle Schools

For middle school installations, standard rack units of four (capacity of eight bicycles) will be used. In most cases, surface mounts on concrete pads will be used, though in-ground mounts are available for use in asphalt or soil. The pad should be 6.25 x 11.5 feet for a unit surrounded by soil, or 3.5 x 9.5 if surrounding by asphalt.

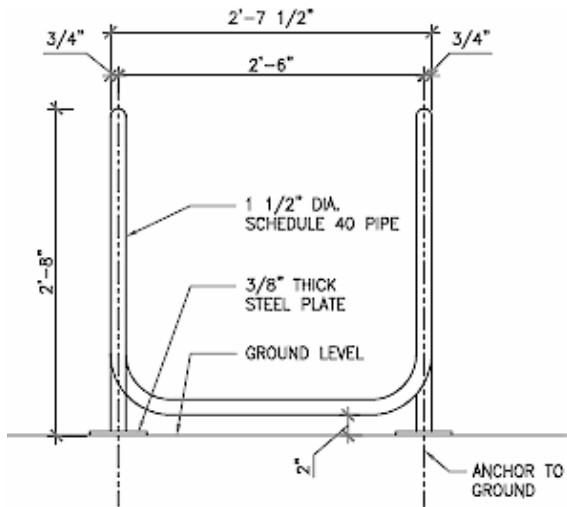
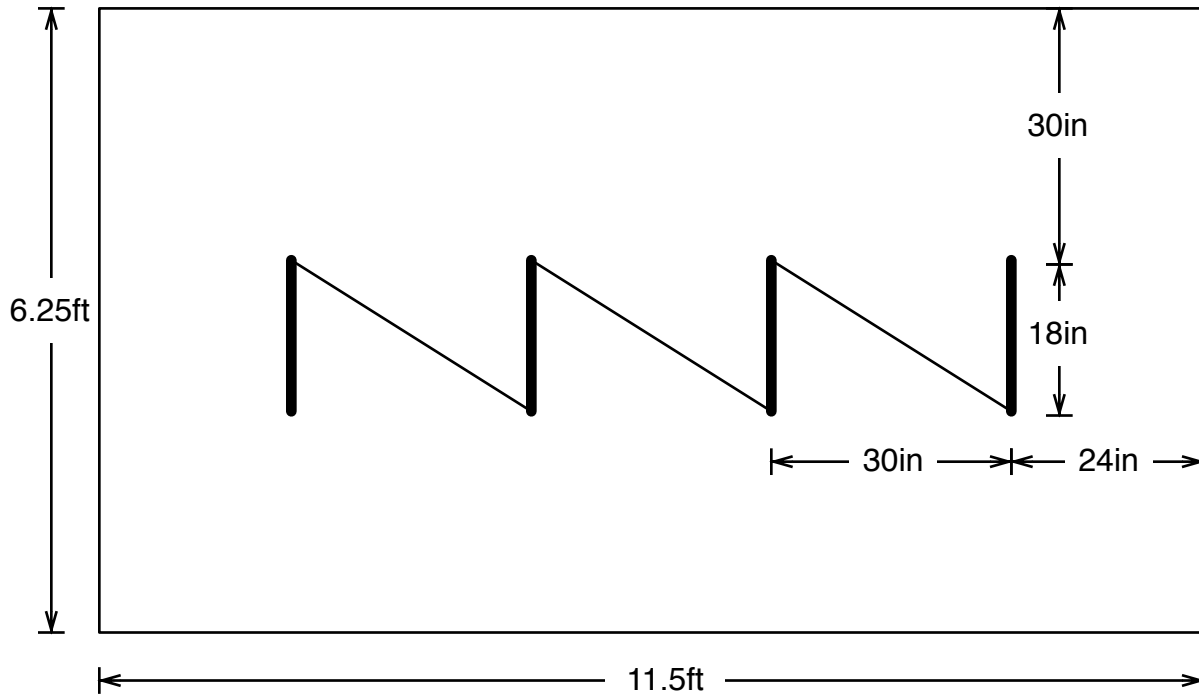

diagrams and photos courtesy of Function First

Function First, Inc.

3935 N. Country Club Rd., #25
Tucson, Arizona 85716

bikeribs@yahoo.com

Phone # 520 322 9626

Fax # 520 844 1110

Estimate

Date	Estimate #
1/27/2009	209

Name / Address
SRTS Carson City 1402 W King St Carson City, NV 89703

Project

Description	Qty	Rate	Total
Bike Rib Series III #BR8 s.m. surface mount bike rack Powder Coat Paint finish - GN03	1	495.00	495.00
Shipping	1	140.00	140.00
Thank You		Total	\$635.00